

CATV 860 MHz Optical Receiver Module

1. Product profile

1.1 General description

High dynamic range optical receiver amplifier module is in a standard SOT115U package where the 0.9mm buffered fiber has an FC/APC or SC/APC connector. The amplifier supply voltage is 24 V (DC).The modules have a single mode optical input suitable for 1290 nm to1600 nm wavelengths,output having a characteristic impedance of 75Ω.

CAUTION



This device is sensitive to Electro Static Discharge (ESD).. Therefore care should be taken during transport and handling.

1.2 Features and benefits

- Large range of optical power input
- Excellent linearity
- Low noise
- Excellent flatness
- Standard CATV outline

1.3 Applications

- CATV optical node systems operating in the 40 MHz to 860 MHz frequency range.

1.4 Handling

- Fiberglass optical coupling:
Maximum tensile strength= 5 N;
Minimum bending radius=35mm.

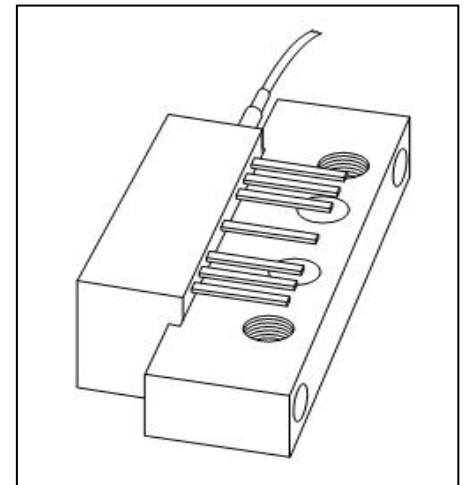

2. Pin information

Pin	Description
1	monitor current
2	Common
3	Common
5	+VB
7	Common
8	Common
9	Output

Simplified outline

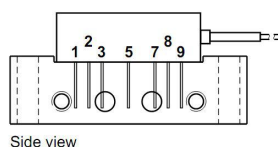

Graphic symbol

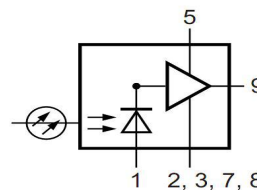

Monitor current

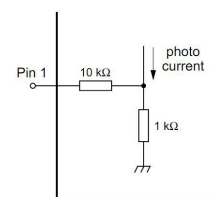

3. Operating conditions

3.1 Limiting values

In accordance with the Absolute Maximum Rating System (IEC 60134) (TA = +25°C)

Parameter	Symbol	Min	Max	Unit
Supply Voltage	V _B	-	25	V
Optical Input Power (continuous)	P _i	-	3	mW
Operating Case Temperature	T _c	-20	+90	°C
Storage Temperature	T _{stg}	-40	+100	°C
ESD sensitivity [1]	ESD	500	-	V

[1] Human body model, R=1.5k, C = 100 pF

3.2 Recommended operating conditions (Z_S = Z_L = 75 Ω)

Parameter	Symbol	Test Conditions	MIN.	TYP.	MAX.	Unit
Supply Voltage	V _B		23.5	24.0	24.5	V
Optical Input Power	P _i	Continuous	-8	-2	+2	dBm
Operating Case Temperature	T _c		-20	+30	+80	°C

4. Electrical characteristics

Bandwidth 40 to 860 MHz , T C = 30±5°C, V B = 24 V, Z S = Z L = 75 Ω

Parameter	Symbol	Test Conditions	MIN.	TYP.	MAX.	Unit
Responsivity[1]	S	λ = 1300 nm, f = 860MHz	800	-	1000	V/W
Flatness straight line (peak to valley)	FL	f = 40 to 860 MHz	-	-	1.0	dB
Slope straight line	SL	f = 40 to 860 MHz	0	1.0	2.0	dB
Output Level	V _o	Optical power receiving at 0dBm	86	87	89	dBuV
Optical input return losses			45	-	-	dB
Output Return Loss	S ₂₂	f = 40 to 860 MHz	10	-	-	dB
Composite Triple Beat	CTB	60channels,m=3.7%, flat output level across the band	-	-70	-	dB
Composite 2nd Order Beat	CSO	P _i =0dBm, measured at 543.25 MHz,	-	-64	-	dB
Equivalent noise input	F	f = 40 to 860 MHz	-	-	7	pA/√Hz
Spectral sensitivity	S _λ	λ = 1310±20 nm	0.85	-	-	A/W
		λ = 1550±20 nm	0.90	-	-	A/W
Operating Current	I _{tot}	V _B =24VDC	110	120	140	mA
Voltage of monitor current pin (pin1)	V _{pin1}	V _B =24VDC, P _i =0dBm	0.85	-	1.05	V
Optical wavelength	λ	1290 – 1600 nm	1290	-	1600	nm
Length of fiber; SM type; 9/125um	L		0.75	-	1.0	m

[1] V_{out}(dBmV)=20 x log 10 (Responsivity(v/w) × Optical Input Power(mw) × Modulation Index / √2)

5. Package outline

Rectangular single-ended package; aluminum flange; 2 vertical mounting holes; 2 x 6-32 UNC and 2 extra horizontal mounting holes; 7 gold-plated in-line leads. Optical input

SOT115U

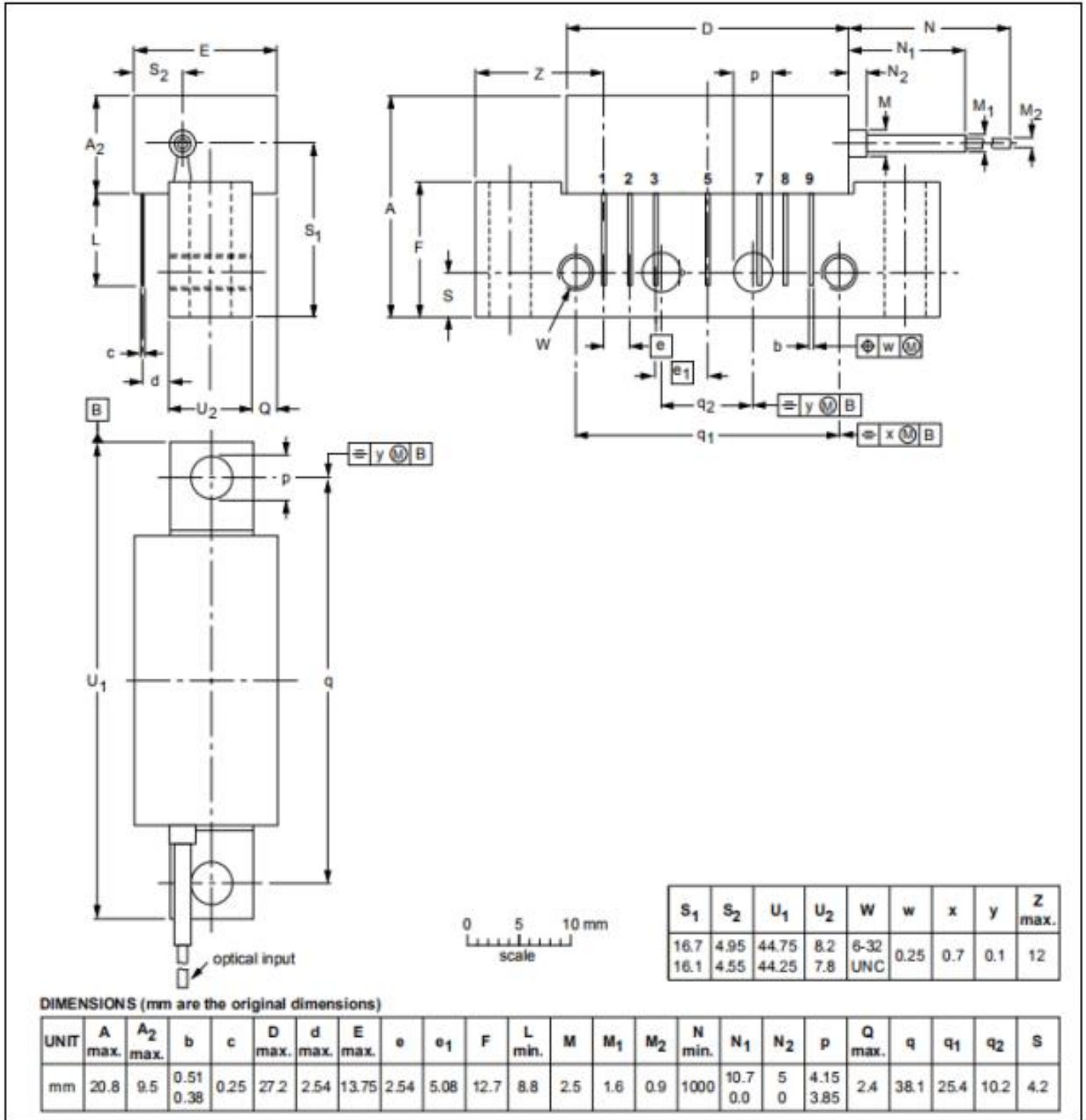

UNIT: mm